

BridoTMlay

User's Guide



TABLE OF CONTENTS

GENERAL INFORMATION	1
1. OBEY THE LEGAL REGULATIONS AND THE APPLICABLE RULES!	1
2. INTENDED USE	1
3. NOT-INTENDED USE	1
4. LIABILITY	1
5. PERSONNEL QUALIFICATIONS	1
6. INFORMATION ABOUT THE RESIDUAL RISKS - USED SAFETY SIGNS	1
7. DISMANTLING, STORAGE, TRANSPORT	2
8. THE LEVEL OF NOISE EMISSION	2
9. MAIN SWITCH	2
10. PROTECTION	2
GENERAL SAFETY RULES	3
OPERATOR'S GUIDE	4
MAINTENANCE INSTRUCTIONS	5
TROUBLE SHOOTING GUIDE	6/8
DECLARATION OF INCORPORATION OF PARTLY COMPLETED MACHINERY	
EC-DECLARATION OF CONFORMITY	

DISCLAIMER : The original, authoritative version of this manual is the Dutch version produced by ROXELL bvba. Subsequent changes to any manual made by any third party have not been reviewed nor authenticated by Roxell. Such changes may include, but are not limited to, translation into languages other than Dutch, and additions to or deletions from the original content. Roxell disclaims responsibility for any and all damages, injuries, warranty claims and/or any other claims associated with such changes, inasmuch as such changes result in content that is different from the authoritative Roxell-published Dutch version of the manual. For current product installation and operation information, please contact the customer service and/or technical service departments of Roxell. Should you observe any questionable content in any manual, please notify Roxell immediately in writing to: ROXELL bvba - Industrielaan 13, 9990 Maldegem - Belgium.

GENERAL INFORMATION

THESE INSTRUCTIONS MUST BE READ, UNDERSTOOD AND ALL POINTS OBSERVED BY THE USER, THE RESPONSIBLE AND OPERATING PERSONNEL.

1. OBEY THE LEGAL REGULATIONS AND THE APPLICABLE RULES!

This concerns, among other things, the European directives transposed into national legislation and/or the laws, safety and accident prevention regulations that apply in the user's country.

During assembly, operation and maintenance of the installation the legal regulations concerned and the applicable technical rules must be obeyed.

2. INTENDED USE

The installation has been designed solely for intensive livestock use and has been developed according to the applicable rules of good workmanship. Extra loading of the product is therefore prohibited. Any other use is considered to be improper use. The manufacturer is not responsible for damage resulting there from. The user bears sole responsibility.

3. NOT-INTENDED USE

All use different than described in point 2" intended use" is at the responsibility of the end user.

4. LIABILITY

The (Extended) Warranty will not apply if any of the following has occurred: failure to conduct incoming goods inspection with regards to the Products, improper handling, transportation, modification or repair; accident, abuse or improper use; improper assembly, installation, connection or maintenance (having regard to Roxell's most current assembly, installation, connection and maintenance manuals); force majeure; negligence, lack of supervision or of maintenance on the part of customer; normal wear and tear; use of cleansing agents and disinfectants that are excluded in Roxell's most current use and maintenance manuals; use of cleansing agents and disinfectants in violation with the instructions received from the suppliers; or use of the Products in an ATEX-surrounding.

The (Extended) Warranty shall not apply in the event of a defect caused either by materials or accessories supplied by or services rendered by Customer, or by an intervention by a person or entity which is not authorised or qualified for carrying out such intervention. Furthermore, the (Extended) Warranty will only apply if the Products are used in livestock houses and if all parts or components of the Products are supplied by Roxell.

Roxell will not be liable for any damages caused due to improper use, assembly, installation, connection or maintenance of the Products. In this respect, the Customer expressly acknowledges that (i) all use, assembly, installation, connection or maintenance must be done in accordance with Roxell's most current assembly, installation, connection and maintenance manuals and (ii) the electrical installation on which the Products must be connected must be done in accordance with applicable local legislation on electrical installations. Furthermore, the Products must be tested both mechanically and electrically in accordance with state of the art techniques and applicable local legislation.

5. PERSONNEL QUALIFICATIONS

USER:

The person who uses a function or operation of a product for their work or who works on the product. The user must be able to read the instructions for use and fully understand them. The user has knowledge of the functioning and construction of the installation.

TECHNICALLY TRAINED PERSON:





An expert who can assemble and maintain the installation (**mechanically/electrically**), and resolve malfunctions. On the basis of his/her technical training and experience, he/she has sufficient knowledge to be able to assess activities, recognise possible dangers and rectify dangerous situations.

6. INFORMATION ABOUT THE RESIDUAL RISKS - USED SAFETY SIGNS

There are three levels of danger, which you can recognize from the signal word

- * **DANGER**
- * **WARNING**
- * **CAUTION**

The nature and source of the imminent danger and possible consequences of not obeying warnings is stated here!

 DANGER	<p>DANGER indicates a direct imminent danger that can result in a serious or even fatal accident if the safety measures are not respected.</p>
 WARNING	<p>WARNING indicates a possible imminent danger that can result in a serious accident or damage to the product if the safety measures are not respected.</p>
 CAUTION	<p>CAUTION indicates possible, dangerous situations that can result in minor physical injury or material damage if the safety measures are not respected.</p>
	<p>This symbol refers to supporting information.</p>
<p> <input checked="" type="checkbox"/> allowed <input type="checkbox"/> not allowed </p>	

7. STORAGE

Put all parts to be assembled in a room or at a location where the not yet assembled components are protected against weather influences.

8. TRANSPORT

Depending on the size of the parts and according to local circumstances and local legislation, the parts of the machine have to be transported with a forklift.

The forklift must be operated by a qualified person and in accordance with the rules of good workmanship.

When lifting the load, always check if the center of gravity of the load is stable.

9. DISMANTLING

Dismantle the installation and its components in accordance with the environmental legislation of the country or the local authorities applicable at that time. All functioning products and exchange parts must be stored and disposed of in accordance with the applicable environmental regulations.

Environmental information for customers in the European Union



European directive 2002/96/EC amended by the Directive 2008/34/EC requires that equipment that bears this symbol on the product or packaging must not be disposed of with unsorted household waste. This symbol indicates that the product must be disposed of separately. You are yourself responsible for the destruction of this and other electrical and electronic equipment via the disposal channels designated for that purpose by the national or local government. The correct destruction and recycling of this equipment prevents any negative consequences for the environment and health. For more information about destroying your old equipment, contact your local authorities or waste disposal service.

Information about waste disposal - electrical/electronic material for companies

1. In the European Union

If you have used the product for commercial purposes and you want to dispose of it, contact Roxell who will give you information about the return of the product. It is possible that you will have to pay a disposal charge for the return and recycling. Small products (and small quantities) can be processed by the local collection agencies.

2. In other countries outside the European Union

If you want to dispose of this product, contact the local authorities for information concerning the correct disposal procedure.

10. THE LEVEL OF NOISE EMISSION

The noise level of the installation in operation does not exceed 70dB(A).

11. LOCK OUT TAG OUT – LOCK METHOD GENERAL

- Everyone needs his own lock and tag (label), which can't be removed by other persons.
- Inform all persons who are influenced by the procedure.
- Localize all sources of energy (electric, hydraulic, pneumatic).
- Switch off.
- Lock out and tag out.
- Check if the source of energy is switched off.
- Remove any remaining energy.

12. USE PERSONAL PROTECTIVE EQUIPMENT.

Ensure you wear personal protective equipment (gloves, dust masks...).

13. SUFFICIENT LIGHTING - ILLUMINANCE

- **A minimum illuminance of 200 lux is necessary** during usage, maintenance and installation.
- Provide at the installation **(portable) emergency lighting in case of power failure.**

14. ELECTRICAL EQUIPMENT, CONTROL PANELS, COMPONENTS AND DRIVE UNITS

- To operate control panels, there must be **at least 70 cm of free space.**
- Control panels must **always remain closed.** The key of the control panel must be in possession of an authorized person.
- The necessary measures must be taken by the user to keep out **rats, mice and other vermin from the control panels**
- If electrical equipment, control panels, components and drive units are damaged, the system must be stopped **IMMEDIATELY!**
- Electrical equipment, control panels, components and drive units should **NEVER be sprayed with water or other liquid!**
- Electrical equipment, control panels, components and drive units should **NEVER be covered with any material.**

GENERAL SAFETY RULES

BridoLay/Ultraflex Nr: 007...

Automatisch trog voedersysteem voor leghennen
Automatic trough feeding system for Layers

Winching systeem

Liersysteem voor voer- en drinklijnen

Winching system for feed- and drink lines



DANGER

IMPORTANT

**Carefully read the following instructions before
USING the system**

1. Before you do any **repair**, or **maintenance works**, always **disconnect the electricity supply**.
2. Ensure you wear **personal protection equipment** (gloves, dust masks).
3. The system **starts automatically**.
Never use your **hands** at **dangerous locations** (feed intake boots, drive units, control units or outlet holes in the tubes) before you have **completely switched off** the transport system and made sure that **nobody** can **switch it on** without your knowledge.
4. **Never** allow **unauthorized persons** to **enter the house** in your absence.
5. **Be careful** when **lowering** or **winching** up the feeding lines/circuits :
 - **stop** immediately at the slightest hitch.
 - **never** stay **underneath** when lowering or winching up the lines/circuit.
6. If the auger stalls : **immediately** switch **off** the system. Carefully read the trouble shooting guide and strictly follow instructions. Contact a **technically trained person**.
An auger **under tension** can **cause very serious injuries** when released.
7. Regularly check the **elbow/trough and/or tube connections**. Tighten if necessary.
8. Ensure that the **hopper cover (grill)** or **cover** on the 100 kg hopper **closes properly**.
9. Regularly check that the **control unit (pan)** and/or the **motor handy box** are properly closed.



This **SYMBOL** will be used to draw your attention to matters that are of **GREAT IMPORTANCE** for your **SAFETY**.

It means : **WARNING** - follow the safety instructions :
disconnect the current - re-read the safety rules.

In short : **BE ALERT**. **IGNORING** these instructions can cause **SE-RIOUS INJURIES** or even **DEATH**.



OPERATOR'S GUIDE - PRODUCTION

PROGRAM THE MEALS

- * The BRIDOLay system operates fully automatic :
Set correct running time to make one complete round. (Speed of auger = 22m/min. Optional : 30m/min)
- * Set feed level at 70-80% of the auger height.
- * Advice: number of feeding cycles: 3-5
- * Program a stimulation meal (if necessary).
- * Program a start impulse if there is no roost above the feed trough.

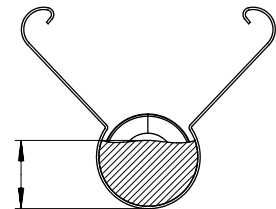
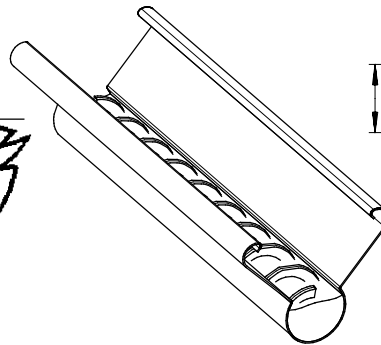
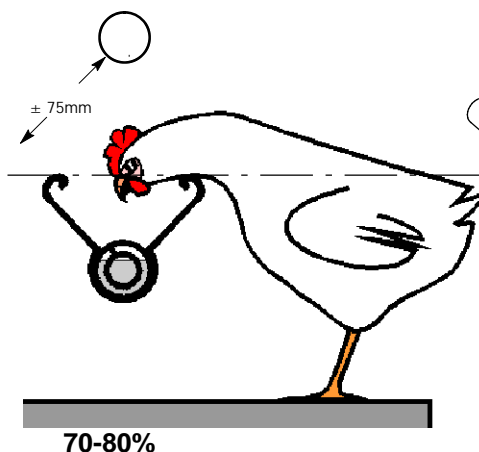
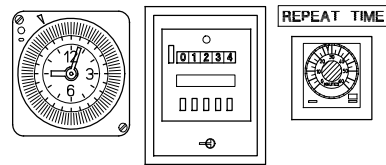

Max. feed height
70-80%

The auger remains visible

CLEANING

- * Before cleaning, remove the feed by emptying the troughs through the cleaning hole.
- * Wrap the motors and the electrical components in a plastic bag to protect them from the high pressure cleaner.
- * Consult your supplier before using any aggressive detergents or disinfectants.
- * Avoid rusting of the auger and the feed troughs after cleaning with water. Let them dry well. Slightly oil them if necessary.

MAINTENANCE INSTRUCTIONS

 DANGER	Switch off the main switch first. Use personal protective equipment.	3-monthly	6-monthly	Yearly
ACTIONS IN GREY BACKGROUND MUST BE DONE BY A TECHNICALLY TRAINED PERSON.				
1. Drive unit				
- Make fan dust-free			X	
- Check possible damages to electrical wiring				X
- Clean gear housing				X
- Check possible damage to drive gear				X
2. Feed intake boot				
- Clean				X
- Check possible wear of plastic gear				X
3. Suspension				
- Check operation of central winch. Grease after cleaning.				X
- Check connection of cable			X	
- Check connection of pulleys			X	
- Check suspension of troughs and motors		X		
4. Poultry perch cable above the elbows				
- Check cable		X		
5. Feed troughs				
- Check possible damages to feed troughs		X		
- Check all trough connections (bolts & nuts)		X		
6. Flex-Auger				
- Check FA suspension				X
- Check operation of safety switch			X	
- Clean the motor			X	
- Check electrical wiring				X

TROUBLE SHOOTING GUIDE

**Switch off the main switch first.
Use personal protective equipment.**



DANGER

ACTIONS IN GREY BACKGROUND MUST BE DONE BY A TECHNICALLY TRAINED PERSON.

FOR ANY AUTOMATIC OPERATION, NONE OF THE YELLOW LAMPS SHOULD BURN !

PROBLEM	LAMP	MAN/ AUT.	CAUSE	CORRECTIVE ACTION
1. No operation possible.	NO	MAN/ AUT.	No current.	Check main switch and/or fuses and/or line current.
2. FA bin to weigher does not run.	NO	MAN.	a. Operation button not on MAN position.	Adjust button.
			b. Remote control not properly plugged.	Check plug.
	NO	MAN./ AUT.	c. Max. switch of weigher remains activated.	Check max. switch and repair or replace it if necessary.
			d. FA safety switch is activated.	Disengage safety switch and find cause of blockage.
	YES	AUT.	e. Reverse switch in position "reverse" (inside the control panel).	This is no breakdown, but it prevents automatic operation. Put switch in position "forward".
	YES	AUT.	f. FA operation button in position "0" or "II".	This is no breakdown, but it prevents automatic operation. Put button in position "I".
	YES	MAN.	g. Thermal-magnetic switch-off of the FA.	Check fuses. Check adjustment of motor protection. Reload motor protection and check its proper operation.
	YES	AUT.	h. See 2.g.	
3. FA weigher-to-circuits does not run.	NO	MAN	a. See 2.a.	
			b. See 2.b.	
			c. Sensor remains activated. See signal lamp sensor.	Check and repair.
	NO	MAN/ AUT	d. See 2.c. and 2.d.	
	YES	MAN/ AUT	e. FA operation button in position "0" or "II". - See 2.e. - See 2.g.	Put button in position "I".
4. FA weigher-to-circuits short cycles.	YES	MAN/ AUT	a. Sensor not properly installed.	See Installation instructions.
			b. Timer of sensor adjusted too low.	Adjust timer on a higher value.

PROBLEM	LAMP	MAN/AUT.	CAUSE	CORRECTIVE ACTION
5. Circuit does not run.	NO	AUT.	a. Panel with time clock and preselection counter : - wrong programming of time clock or counter or no programming at all.	Check programming.
			b. Panel with computer : - wrong programming of computer or no programming at all.	Check instructions computer.
			c. See 2-e.	
	YES	MAN	d. Operation button of circuit in position "0".	This is no breakdown, but it prevents automatic operation.
			e. Left or right hand motor switched-off thermal-magnetically without being overloaded.	Check fuses. Check adjustment of motor protection. Reload motor protection and check its proper operation.
			f. Left or right hand motor overloaded. (1 or more circuits). 1. Too much feed in the troughs. 2. Connector intake boot/trough not properly tightened. 3. Auger coupling not properly installed. 4. Auger kinked as a result of careless installation. 5. Wheel inside intake boot is blocked. 6. Obstruction in the trough.	Have troughs emptied by the birds and then adjust feeding programme. Firmly tighten the connector. Check auger couplings and replace if necessary Replace damaged auger.
				Disengage wheel or replace if necessary.
				Find blocking spot and remove the obstruction. SEE NOTE .
	YES	AUT.	g. Operation button of one or more circuits in position "0".	This is no breakdown, but it prevents automatic operation. Put in position I.
			h. See 5.e.	
i. See 5. f.				
j. See 2. e.				



NOTE : IF THE AUGER OF THE CIRCUIT IS BLOCKED AS A RESULT OF ONE OF THE ABOVE PROBLEMS, IT WILL BE UNDER SPRING TENSION, SO BE EXTREMELY CAREFUL AND PROCEED AS DESCRIBED IN THE NEXT PAGE*

DANGER

6. Circuit : - stops prematurely. - does not stop in time.	YES	AUT.	a. Time set on time clock is not sufficient.	Adjust time clock programming.
			b. Timer not properly set (timer 0-999" inside control panel).	Adjust timer programming. (1 sec = 0,5m).
			c. See 6.b.	

PROBLEM	LAMP	MAN/AUT.	CAUSE	CORRECTIVE ACTION
7. Auger runs erratically.	YES	AUT.	a. When using the system for the first time.	This is not a breakdown; it will be OK after a couple of days.
			b. Auger too short.	Adjust auger length.
			c. Auger kinked as a result of careless installation.	Replace kinked parts.
			d. Auger coupling not properly installed.	See instructions. Replace coupling if necessary.
			e. Circuit too long.	Check maximum length and install an extra drive unit if necessary.
			f. Circuit not properly suspended (loose or ineffective suspension).	Realign circuit. Check all suspensions and readjust where needed.



SWITCH OFF THE MAIN SWITCH OF THE CENTRAL CONTROL PANEL BEFORE YOU PROCEED WITH MANUAL CHECKS OR REPAIRS OF AUGERS OR POWER UNITS !

DANGER

*** NOTE : WHEN THE AUGER IS BLOCKED, PROCEED AS FOLLOWS :**

1. Locate the blocking spot precisely.
2. Put operation button in the central control panel in position MANUAL.
3. Put the reverse switch in the central control panel in position "reverse".
4. Connect the remote control.
5. Reload the motor protection (left or right).
6. Let the auger run backwards a couple of metres, find the cause (pag 7 f.) and correct.
7. Put the reverse switch in position "forward" and make sure that the auger runs smoothly again.
8. Put operation button in position AUTO. The circuit is ready for a new feeding cycle.



Inbouwverklaring betreffende niet voltooide machines (Richtlijn 2006/42/EG, Bijlage II.1.B)
Declaration of incorporation of partly completed machinery (EC-Directive 2006/42/EC, Annex II.1.B)

Fabrikant/Manufacturer:
Roxell, Industrielaan 13, 9990 Maldegem
Tel: +32 50 72 91 72
Fax: +32 50 71 67 21

Verklaart geheel onder eigen verantwoordelijkheid dat het product:
Declares on its own responsibility that the product:

BRiDOLay/Ultraflex Nr.: 007...
Automatisch trog voedersysteem voor leghennen.
Automatic trough feeding system for Layers.

Waarop deze verklaring betrekking heeft, in overeenstemming is met:

- de volgende richtlijnen: 2006/42/EG (Machinerichtlijn); 2014/30/EU (Elektromagnetische Compatibiliteit).
- de geharmoniseerde Europese Normen: EN ISO 13857:2008; EN 349:1993 + A1:2008; EN ISO 12100:2010; EN 60204-1:2006; EN 61439-1:2011; EN 61439-2:2011

Het is verboden bovengenoemd product in gebruik te stellen voordat de machine waarin het wordt ingebouwd in overeenstemming met de bepalingen van de Machinerichtlijn is verklaard.

Tevens verbindt de fabrikant (of zijn gemachtigde) zich om op met redenen omkleed verzoek van de nationale autoriteiten de relevante informatie over deze niet voltooide machine door te geven. De wijze van doorgifte is digitaal. De wijze van informatieverstopping laat de intellectueel-eigendomsrechten van de fabrikant van de niet voltooide machine onverlet.

(NL)

Relating to this declaration, is conform

- The following directives 2006/42/EC (Machinery Directive); 2014/30/EU (Electromagnetic Compatibility).
- The harmonised European standards: EN ISO 13857:2008; EN 349:1993 + A1:2008; EN ISO 12100:2010; EN 60204-1:2006; EN 61439-1:2011; EN 61439-2:2011

This product must not be put into service until the machinery into which it is to be incorporated has been declared in conformity with the provisions of the Machinery Directive.

The manufacturer (or its agent) also undertakes, at the duly reasoned request of the national authorities, to provide the relevant information concerning this partly completed machinery. The method of transmission will be digital. The manner in which the information is provided does not prejudice the manufacturer's intellectual property rights concerning the partly completed machinery.

(EN)

Plaats, Datum / Place, Date : Maldegem, 01/01/2017

00706408

.....
Dhr. Gino Van Landuyt
Managing Director

“This part may only be filled out if all built-in subparts are delivered by Roxell”

EG-verklaring van overeenstemming (Richtlijn 2006/42/EG, Bijlage II.1.A)
EC-declaration of conformity (EC-Directive 2006/42/EC, Annex II.1.A)

Wij/We _____
(naam installateur/name fitter)

(volledig adres en land/complete address)

Verklaren geheel onder eigen verantwoording de
Declare completely on own justification that

(naam machine/name machinery) (nummer CE-label/number CE-label)

In een installatie te hebben ingebouwd geheel volgens de Roxell-voorschriften en in overeenstemming met de bepalingen van de Machinerichtlijn.
Has been incorporated in conformity with the provisions of the Machinery Directive and the prescriptions of Roxell bvba.

(plaats, datum/place, date) (naam, handtekening/name, signature)

De EG-verklaring van overeenstemming / inbouwverklaring betreft uitsluitend de machine of niet voltooide machine in de toestand waarin zij op de markt is gebracht, met uitsluiting van de later bijvoorbeeld door de verdeler en/of installateur en/of eindgebruiker toegevoegde componenten en/of verrichte bewerkingen.

The EC-declaration of conformity / declaration of incorporation relates exclusively to the machinery or partly completed machine in the state in which it was placed on the market and excludes components which are added and/or operations carried out thereafter for instance by the distributor and/or the installer and/or the final user.



EG-verklaring van overeenstemming (*Richtlijn 2006/42/EG, Bijlage II.1.A*)
EC-declaration of conformity (*Directive 2006/42/EC, Annex II.1.A*)

Fabrikant/Manufacturer:
 Roxell, Industrielaan 13, 9990 Maldegem
 Tel: +32 50 72 91 72
 Fax: +32 50 71 67 21

Verklaart geheel onder eigen verantwoordelijkheid dat het product:
 Declares on its own responsibility that the product:

Winching system Nr: 00102368 / 00102087
 Liersysteem voor voer- en drinklijnen; manueel en gemotoriseerd
 Winching system for feed- and drink lines; manual and motorised
 Nummer CE-label/number CE-label : _____

Waarop deze verklaring betrekking heeft, in overeenstemming is met:

- de volgende richtlijnen: 2006/42/EG (Machinerichtlijn); 2014/30/EU (Elektromagnetische Compatibiliteit).
 - de geharmoniseerde Europese Normen: EN ISO 13857; EN 349:1993 + A1:2008; EN ISO 12100:2010; gemotoriseerd: EN 60204-1:2006; EN 61439-1:2011; EN 61439-2:2011
- De EG-verklaring van overeenstemming / inbouwverklaring betreft uitsluitend de machine of niet voltooide machine in de toestand waarin zij op de markt is gebracht, met uitsluiting van de later door bijvoorbeeld de verdeler en/of installateur en/of eindgebruiker toegevoegde componenten en/of verrichte bewerkingen.

(NL)

Relating to this declaration, is conform

- The following directives 2006/42/EC (Machinery Directive); 2014/30/EU (Electromagnetic Compatibility).
 - The harmonised European standards: EN ISO 13857:2008; EN 349:1993 + A1:2008; EN ISO 12100:2010; motorised: EN 60204-1:2006; EN 61439-1:2011; EN 61439-2:2011

The EC-declaration of conformity / declaration of incorporation relates exclusively to the machinery or partly completed machine in the state in which it was placed on the market and excludes components which are added and/or operations carried out thereafter for instance by the distributor and/or the installer and/or the final user.

(EN)

Plaats, Datum / Place, Date : Maldegem, 01/01/2017

.....
 Dhr. Gino Van Landuyt
 Managing Director

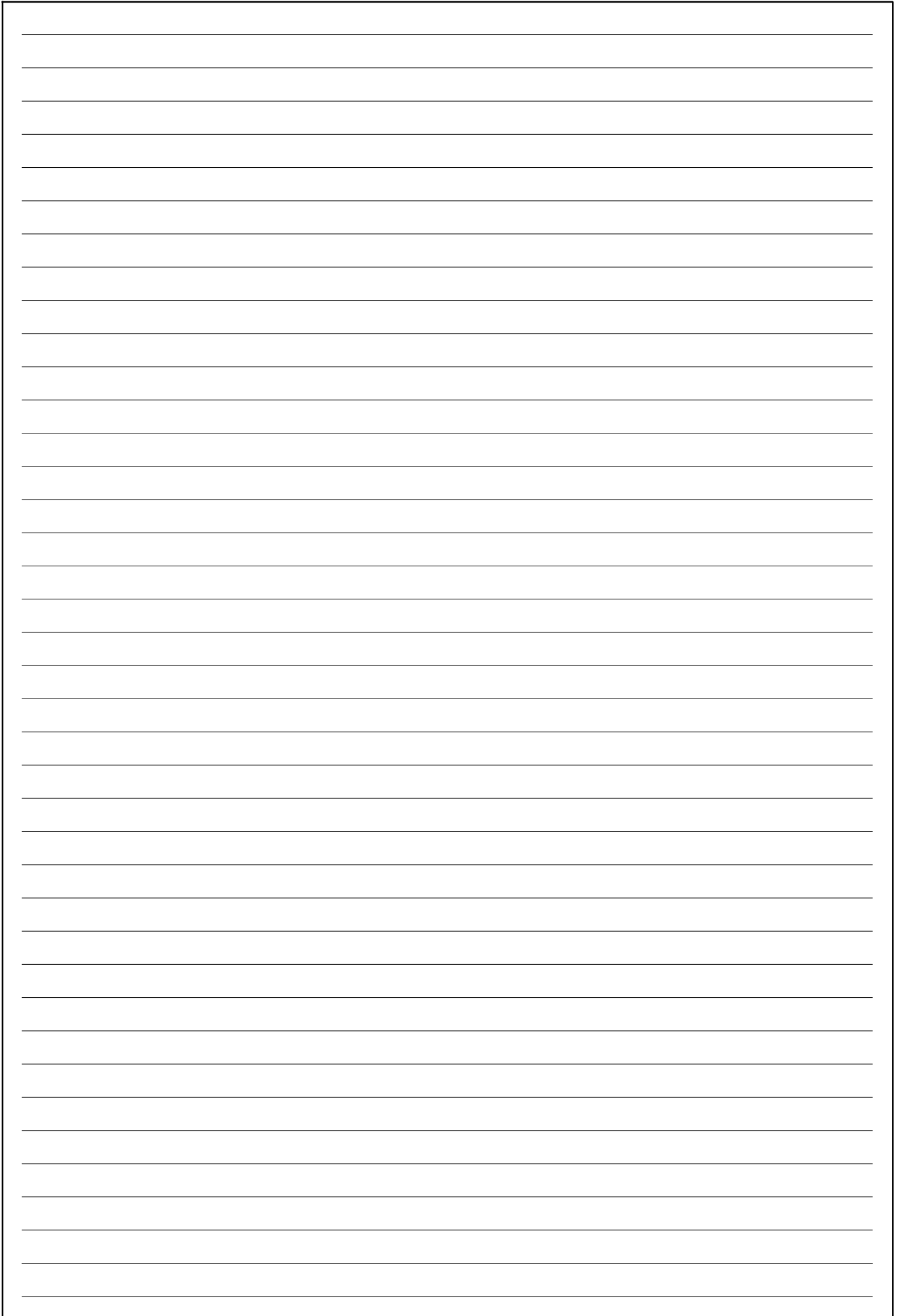

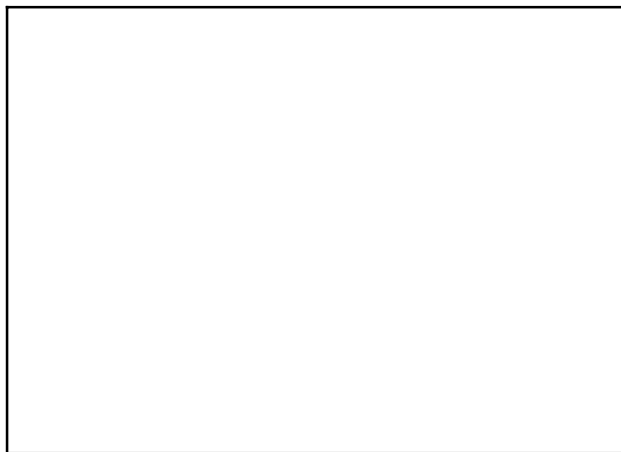

ROXELL bvba, Industrielaan 13, B-9990 Maldegem (Belgium)
Tel. +32 50 72.91.72 - Fax. +32 50 71.67.21 - E-mail info@roxell.com - Website www.roxell.com

ROXELL Russia, LLC Roxell, Leningradskiy Prospekt 37, bld. 9, premise № 653, 125167 Moscow, Russian Federation -
OGRN : 1157746055026
Tel: +7 495 9833015 - E-mail info.russia@roxell.com - Website www.roxell.com

ROXELL Malaysia - No. 12 Jalan Anggerik Mokara31/48, Kota Kemuning - Industrial Park, 40150 Shah Alam, Selangor,
Malaysia - Tel: +603 5121 7148 or +603 5121 7150 - Fax: +603 5121 7146 - A division of CTB Malaysia Sdn. Bhd.
(868715-X) - E-mail: info.malaysia@roxell.com - www.roxell.com

ROXELL USA, Inc. - 720 Industrial Park Road - Anderson, MO 64831 (USA)
Phone +1 417 845-6065 - Fax. +1 417 845-6069 - E-mail info.usa@roxell.com - Website www.roxell.com